

2.50mm & 3.50mm STEREO JACK

COMPACT PC BOARD MOUNT STEREO JACKS



SPECIFICATIONS

Material:

Insulator: PBT, glass reinforced thermoplastic, rated UL 94V-0
Contacts: Phosphor Bronze

Plating:

100 µin tin-lead over 50 µin copper underplate



Electrical:

Operation Voltage: 250 VAC max
Current Rating: 1 Amp max
Contact Resistance: 20Ω max
Insulation Resistance: 5000 MΩ min @ 1000 VAC between adjacent contacts (75°F and 50% R.H.)
Dielectric Withstanding Voltage: 1000 VAC min rms (sea level)
Capacitance: 1.5 pF max between adjacent contacts



ORDERING INFORMATION

choose one from each category as shown in sample below

SJ	A	3	Options (add as suffix to part number)
Series	Jack Type	Contact Form & Switch Type	
SJ - Stereo Jack	A - H	2 - 5	P - Peg Option H - Hi Temp Insulator S - SMT Leads

SJ TYPE A

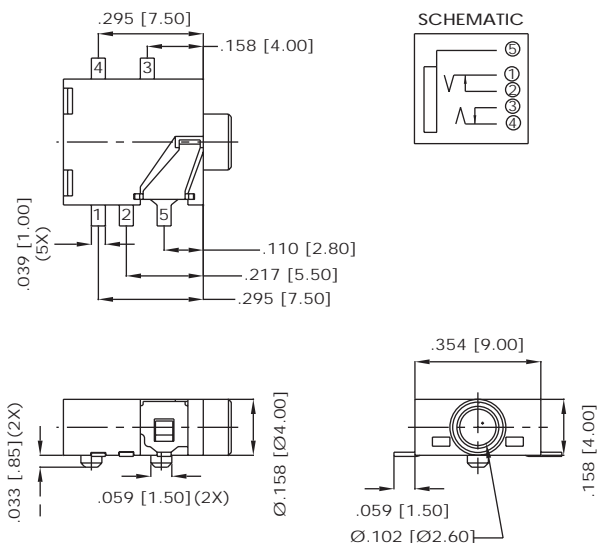

SJ TYPE B

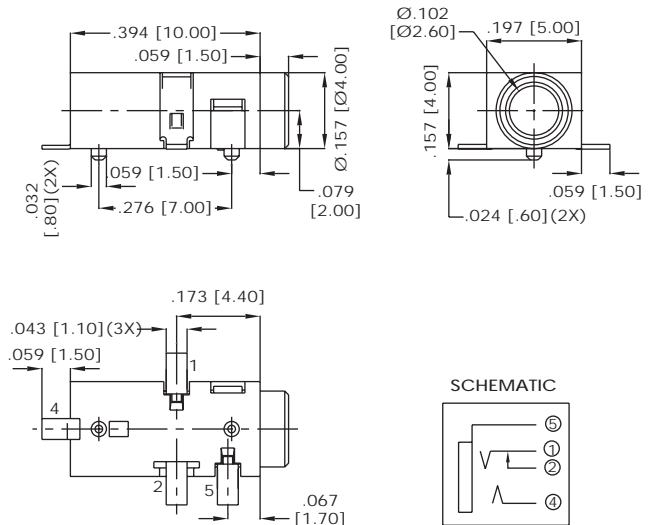

CONTACT FORM CONTACT FORM 2 CONTACT FORM 3 CONTACT FORM 3A CONTACT FORM 4A CONTACT FORM 4B CONTACT FORM 5

SCHEMATIC

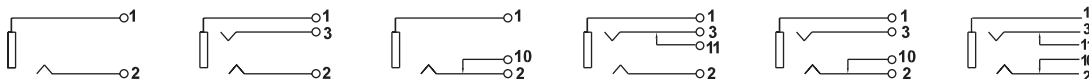

2.50mm & 3.50mm STEREO JACK

COMPACT PC BOARD MOUNT STEREO JACKS



SJ TYPE C

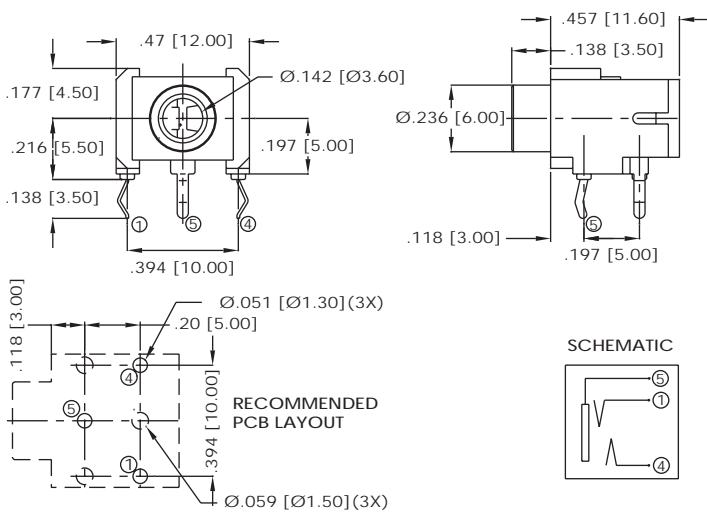

SJ TYPE D

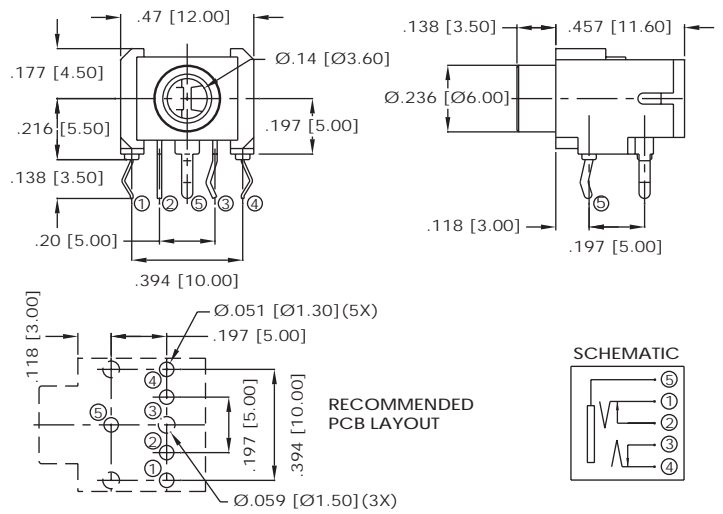

SJ TYPE E

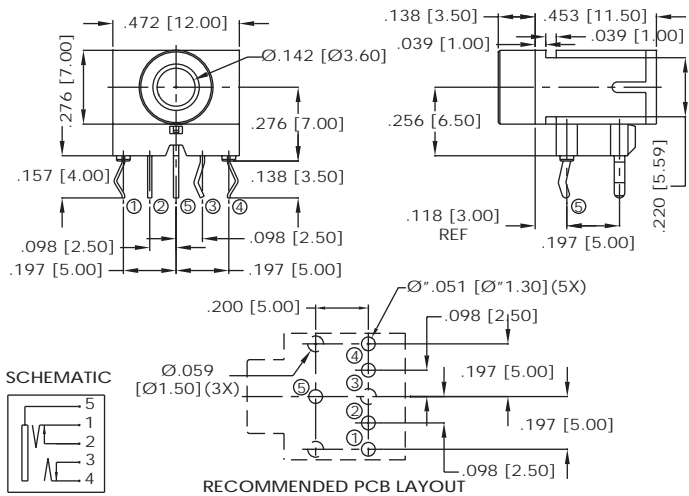

SJ TYPE F

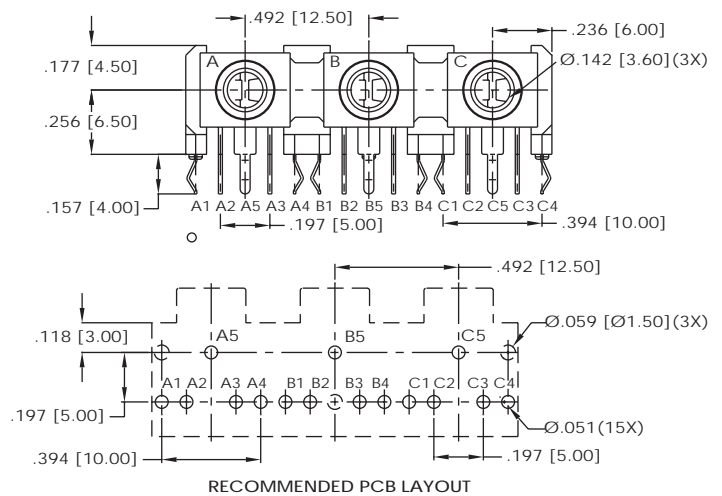

SJ TYPE G

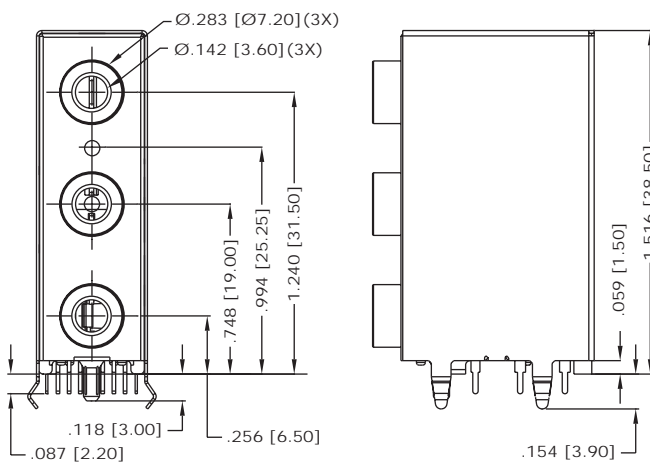

SJ TYPE H

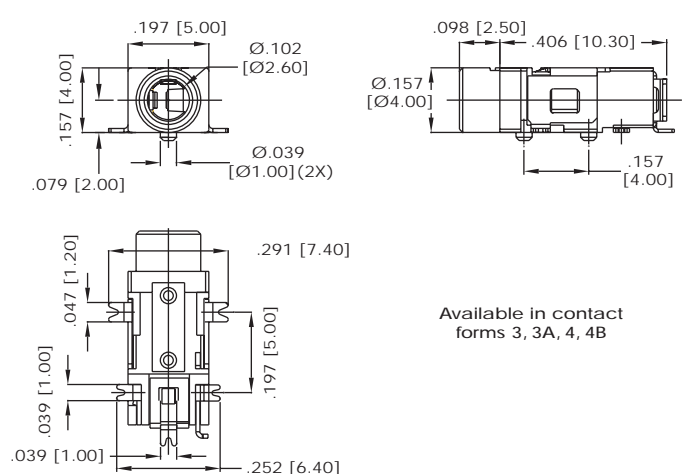

Available in contact forms 3, 3A, 4, 4B